

**Sevenstar**

D07 – 60G	Mass Flow controller
D07-60GM	Mass Flow Meter

## INSTRUCTION MANUAL



北京七星华创流量计有限公司  
Beijing Sevenstar Flow Co.,Ltd.

2017.03



## **A NOTE TO OUR CUSTOMERS**

The Sevenstar D07 series Mass Flow Meter/Controller you have just received is of the leading quality available. It includes excellent high degree of accuracy and repeatability, in addition to the variety of operation pressure available. It offers soft-start, tightly controlled response and maximum applications flexibility.

We strongly recommend that you read this manual thoroughly before performing any operation. This manual will enable the full information necessary for installation, operation and ease of maintenance to be realized.

Should you require any additional information concerning the Sevenstar D07 series Mass Flow Controller or Mass Flow Meter, please feel free to contact your local Sevenstar Sales Agent or Sevenstar Customer Service at: (8610)--- 6436 2939.

We appreciate this opportunity to service your Mass Flow Meter/Controller, and hope we will be able to provide you with further assistance in future.

Yours sincerely,

Sevenstar

# 目 录

1. APPLICATION & FEATURES.....	1	5.2.2 Zero Test and Adjustment.....	16
2. SPECIFICATION.....	2	5.2.3 Gas Supply.....	16
3. STRUCTURE & PRINCIPLE.....	3	5.2.4 Shut Off.....	16
3.1 Structure.....	3	6. CAUTION.....	16
3.2 Operation Principle.....	3	6.1 Medium Forbidden .....	16
4. INSTALLATION & CONNECTION .....	5	6.2 Corrosive Gas .....	16
4.1 Dimension.....	5	6.3 Valves Dynamic Sealing .....	17
4.2 Fittings.....	9	6.4 Valves Operating .....	17
4.3 Electrical Interfacing.....	10	6.5 Installation Position .....	17
4.4 PC Connection.....	11	6.6 Operation Pressure Resistance.....	17
4.5 Zero Adjustment.....	13	6.7 Calibration and Conversion.....	17
5. OPERATION INSTRUCTIONS.....	14	6.8 D07-60G, 60GM Ordering Code.....	18
5.1 MFC Operation.....	14	7. TROUBLESHOOTING.....	21
5.1.1 Start Up.....	14	8. WARRANTY & SERVICE.....	23
5.1.2 Purge.....	15	8.1 Product Warranty.....	23
5.1.3 Readout Box & PC Connection.....	15	8.2 Specific warranty requirements .....	23
5.1.4 PC Connection.....	15	8.3 Service.....	23
5.1.5 Valves Control.....	15	9. APPENDIX.....	24
5.1.6 Shut Off Operation.....	15	9.1 Mass Flow Conversion factors.....	24
5.2 MFM Operation.....	16	9.2 Conversion factors Introduction.....	26
5.2.1 Start Up .....	16		

## Operating Instruction

### 1. APPLICATION & FEATURES

Mass Flow Meter (MFM) accurately measures mass flow rates, Mass Flow Controller (MFC) accurately measures and controls mass flow rates despite gas volume fluctuation due to pressure or temperature changes. They are widely applied in the fields as: semiconductor and IC fabrication, special materials science, chemical industry, petrolic industry, pharmaceutical industry, environmental protection and vacuum system researching, etc. The typical applications include: microelectronic process equipment such as diffusion, oxidation, epitaxy, CVD, plasma etching, sputtering, ion implantation; vacuum deposition equipment, optical fiber melting, micro-reaction equipment, mixing & matching gas system, capillary flow control system, gas chromatograph and other analytical instruments.

D07 series MFM & MFC bring the high accuracy, excellent repeatability, quick response, soft-start, better reliability, wide variety ranges of operation pressure (good operation in high pressure and vacuum situations), simple convenient operation, flexible installation, possible connecting with PC to carry out automatic control to the users' system.

D07-60G、D07-60GM all use 24 VDC power supply, and they are better connected together with D08-1K Readout Box, the cable connection is showing as following (Figure 1):



Figure 1 D07-60G MFC and Readout Box

## 2. SPECIFICATION

Table 1. Specifications of D07-60G MFC and D07-60GM MFM

NO	Item	D07-60G	D07-60GM
1	Flow Ranges	300, 500, 750, 1000, 1500, 2000SLM	
2	Accuracy	±2% F.S.	
3	Linearity	±1% F.S.	
4	Repeatability	±0.2%F.S.	
5	Response-Time	< 10 sec	
6	Operation Pressure	(0.25 ~ 0.5) MPa (≤1000SLM) (0.4 ~ 0.6) MPa (>1000SLM)	<0.2 MPa
7	Max Pressure	3 MPa	
8	Operation Temperature	5~ 45 °C	
9	Input Signal	4~20 mA or 1~5 VDC	NO
10	Output Signal	4~20 mA or 1~5 VDC	
11	Valve Type	N.C. Solenoid	NO
12	Power Supply	+24VDC 400 mA	+24VDC 400 mA
13	Dimension (mm)	According to Figure 3a、3b、3c、3d	
14	Weight (kg)	6	5

### Notes

MFC/MFM is calibrated by N<sub>2</sub> as a standard gas.

Units: SCCM (Standard Cubic Centimeter/Min);

SLM (Standard Liter/Min)

Standard Situation: Tem — 273.15K (0 °C);

Air Pressure — 101325 Pa (760mm Hg)

For Sevenstar MFC/MFM, the unit of SCCM is identical to “mL/min, 0 °C ,1atm”, and the unit of SLM

is identical to “L/min, 0 °C ,1atm”.

F.S. :

Full Scale

### **3. STRUCTURE & OPERATION PRINCIPLE**

#### **3.1 Structure**

The MFM consists of flow sensor, flow-splitter bypass and flow amplifying circuit. If add Control valves and PID control circuit to MFM will compose a MFC.

#### **3.2 Operation Principle**

According to the Capillary Heat Transfer Temperature Difference Calorimetry Theory, the flow sensor measures the mass flow without pressure compensation. The sensor heated the flow signal which was measured by electric bridge and amplified it through amplifier, the amplified flow testing voltage is compared with presetting voltage, the differential signal will control valve after amplified, then the flow rate of closed loop control will be as same as presetting flow rate. The bypass divider controls the flow rate. The corresponding D08 series Flow Readout Boxes have stabilized power supply, 3 and 1/2 digital voltage meter, presetting potentiometer, external & internal converters and three-phase switches. Figure 2 is exactly showing the operating principle while MFC is connecting with Flow Readout Box.

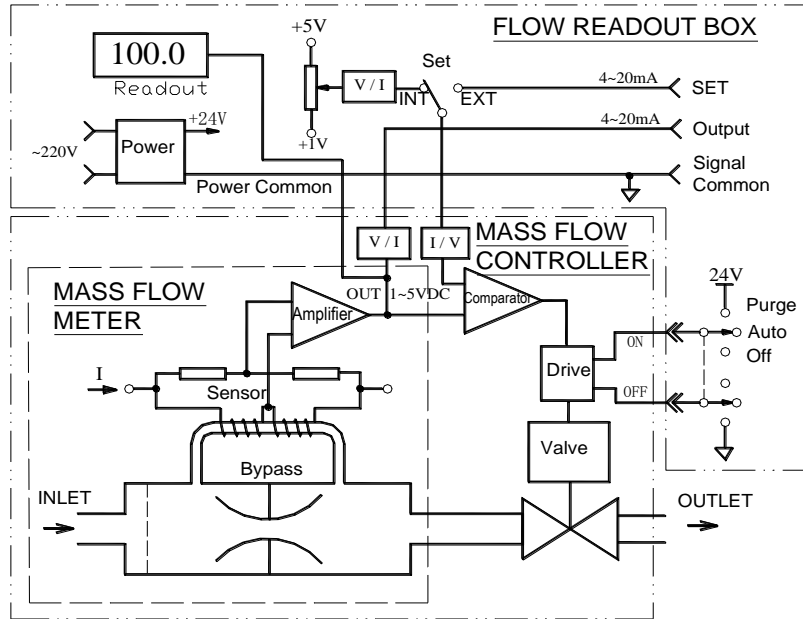

Figure2. Principle of MFC

The outputting flow testing signal from MFC is a direct ratio with the flow through the channels, flow outputting signal is 4~20mA (or 1~5VDC). The Flow control ranges of MFC is (2~100)% F.S.. When the set point <2% F.S. the valve will shut off. MFC and MFM flow resolving power is 0.1% F.S..

## Attention:

When Valve controller of MFC is posited on position of “PURGE”, it can be functioned as a MFM. In that case, the maximum flow testing voltage could reach beyond +10V, please be careful, while flow is beyond F.S. +5V(Full Scale), the real flow will have no linearity corresponding with flow testing voltage. While it's purging, flow display will be inaccurate, even showing “reduce” while the real flow is enhanced, please be sure it'll be no damaged to device itself.

Operation control could accomplish by Flow Readout Box. When set point is turned on the “INT”, flow rate will be under controlled by the presetting potentiometer; when setpoint is turned on the “EXT”, flow rate will be controlled by set signal which is supplied by users.

There are three valves control switches on the panel of D08 series Flow Readout Box: CLOSE, PURGE and AUTO. In case of CLOSE, Valves of MFC will shut off; in case of PURGE, Valve will open reach to the tip to purge the Gas systems or could be functioned as a MFM; when set to AUTO, Valve can control the flow rate automatically.

## **4. INSTALLATION & CONNECTION**

### **4.1 Dimension**

Dimensions and installations are showing as following figure 3a、3b、3c、3d:



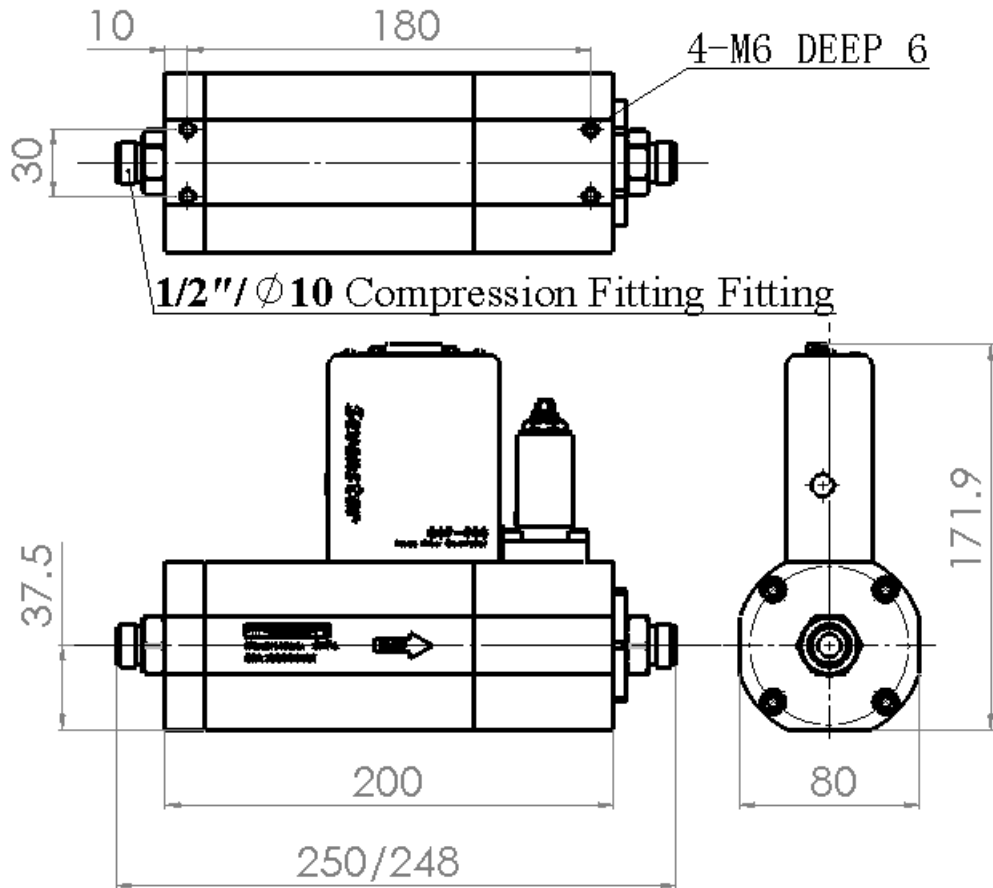
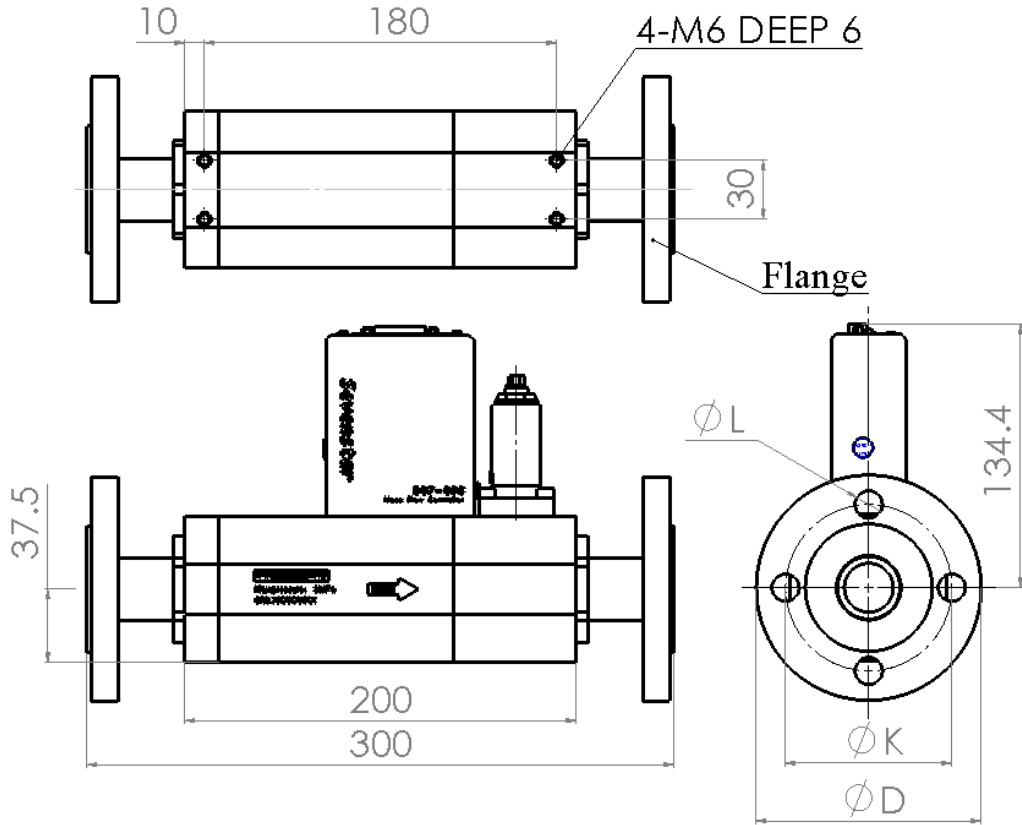
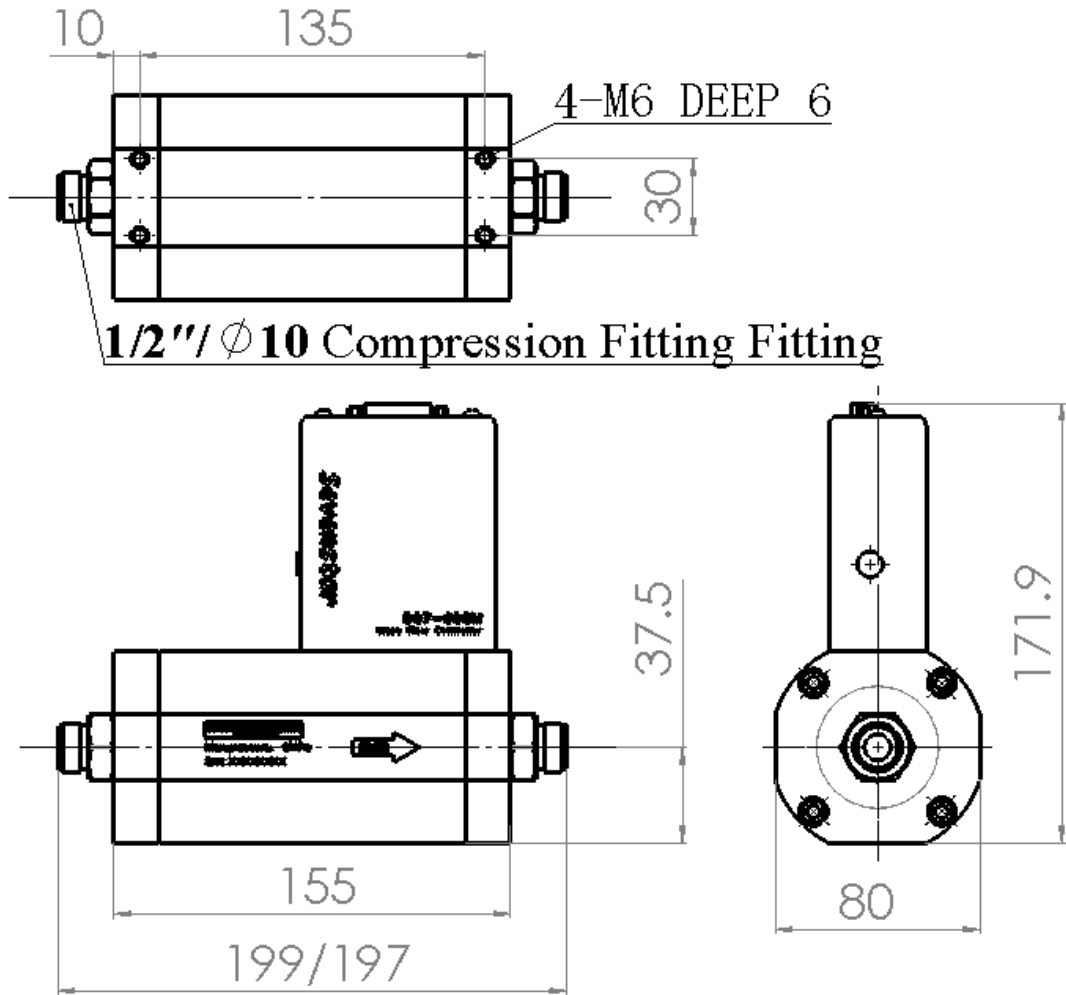

Figure 3a. Dimension of D07-60G MFC With  $1/2'' / \phi 10$  Compression Fitting Fitting



Flange	D	K	L
DIN DN15- PN40	95	65	14
DIN DN20- PN40	105	75	14
DIN DN25- PN40	115	85	14

**Figure 3b. Dimension of D07-60G MFC With Flange**



**Figure 3c. Dimension of D07-60GM MFM With 1/2" /  $\phi$  10 Compression Fitting Fitting**

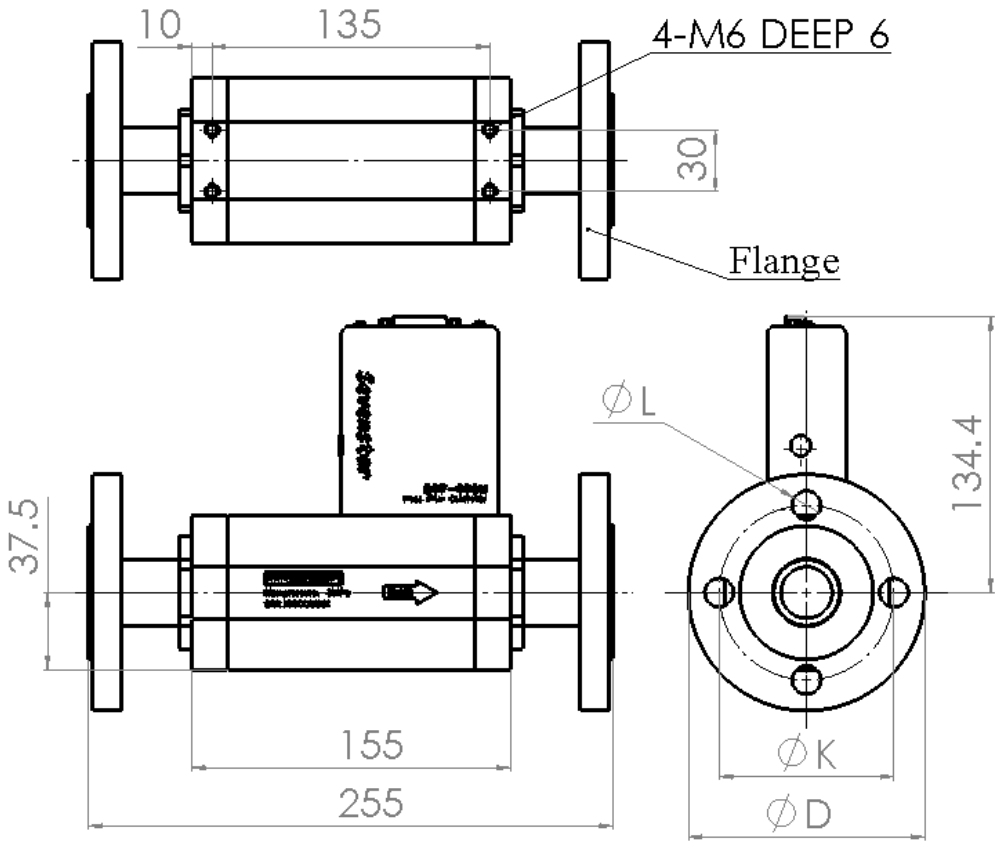

**Figure 3d. Dimension of D07-60GM MFC With Flange**

**Attention:**

The height of figure 3a, 3b, 3c, 3d are height without electric connectors of cable. It should be added around 50mm more after adding the electric connector.

## 4.2 Fittings

Four models of external diameters connectors could be provided:

Table2. Connectors & Dimensions of D07-60G、D07-60GM

No	MFC/MFM Model	Compression Fitting		Note
		$\Phi 10$ (300SLM)	1/2" ( $\leq 1000$ SLM)	
1	D07—60G	○	○	Mark"○" means could be selected, but each model only could be selected one connector type at a time.
2	D07—60GM	○	○	

Using standard Compression Fitting connectors, general speaking, stainless steel tube was used to connect MFC and Gas System, matching to the different request, other materials also could be used as nylon tube or hard flexible plastic hose. Figure 4 is an example to showing the fitting structure, please be careful, the flow input & output direction should not be inversed fitted.

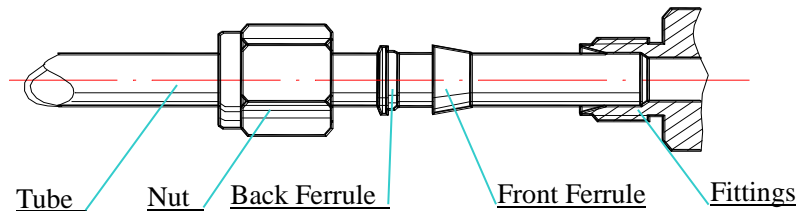

Figure 4. Compression Fitting Connector Installation

### Attention:

For installing the fittings, you should manually use spanner to wrench it tighten by 1/2 turn pulling up, (imported Compression Fitting should use spanner to be tighten in 1.25 turns) to prove its not blow-by after your installing the front ferrule, back ferrule and nut. Please note you should use two spanners to operating, one spanner for locking the fitting stable and another one for revolving the nut. Especially when you dismantle the tube, you should operate by the two spanners otherwise fitting will become flexible which will affect its airproof function.

4.3 Electrical Interfacing

MFC could begin operating after it was well connected with professional cable and corresponding Flow Readout Box. The electrical interfacings of each MFC and MFM are showing as following figures (Figure 5 ~ Figure 6).

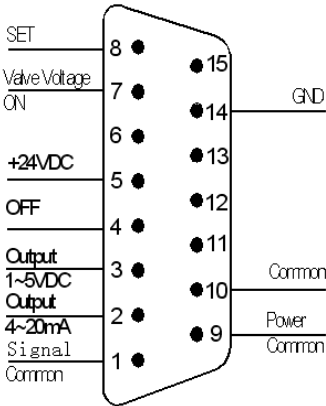

Figure 5. Connection of D07-60G MFC Electrical Interfacing

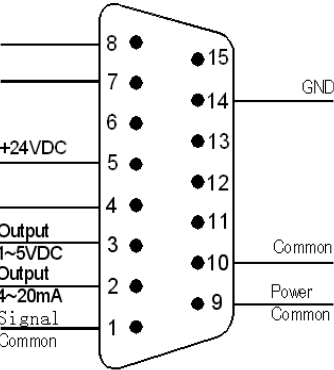

Figure 6. Connection of D07-60GM MFM Electrical Interfacing

#### 4.4 PC Connection

- a. Connection through Flow Readout Box with PC or other external signal. (Figure 7)

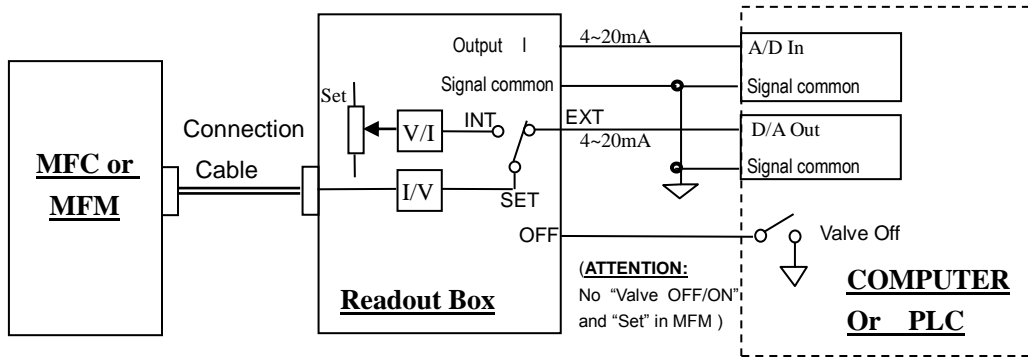

Figure 7. Connection with PC through Readout Box

When need test the output I signal (4~20mA) , users could connect to the “Output I” and the “Signal common” of external control signal socket of Flow Readout Box, also could directly connect with PC modulus (A/D) converter.If flow output signal is voltage signal, +5V output voltage is corresponding as full scale rating flow rate of MFC,+1V output voltage is corresponding as zero scale rating flow. Please be sure the flow testing output electric current will be no more than 3mA.

When the flow is setting by external signals, it should be turned the switch on “EXT”, meanwhile, it should be input 4~20mA external signal from external control socket to the Flow Readout Box. . It also could be directly connecting with modulus (D/A) converter of PC to achieve auto-control.

If PC or PLC need perform the OFF function of valve control, it could be accomplished by use one RELAYS (two sets) transfer contacts, showing in Figure 7.

- b. PC Directly Connections (Figure 8)

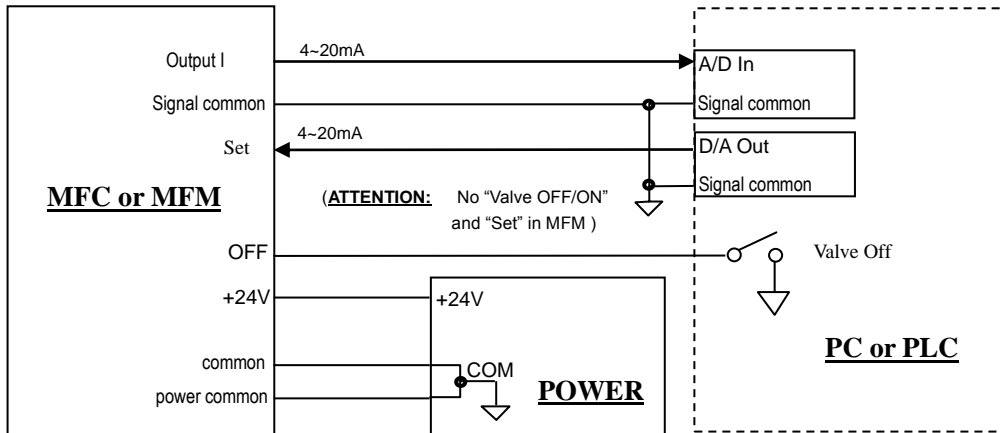

Figure 8. PC Directly Connection

Under the case of MFM/MFC directly connects to PC without Flow Readout Box, 24VDC power supply with good anti-jamming should be provided by user itself; connects SET with PC D/A output; connects "Output I" with PC A/D input; "Signal common" connects signal reference point; low-current "common" and heavy-current "power common" down lead separately, and connects together to the 24VDC power supply common port.



## 4.5 Zero Adjustment

It could be zero adjusted in case of zero excursions while the first time operates or a long period operating. Users could adjust Zero Potentiometer from side face (showing in figure 9) or adjust it while removed its overall. Please note it should be sure that gas flow tube could not be open while zero adjustment (or shutoff the valves); it should be warming up not less than 15 minutes, adjustment performs after its zero moving to the stable stop. Users should not adjust zero except zero potentiometer, otherwise it will affect device accuracy.

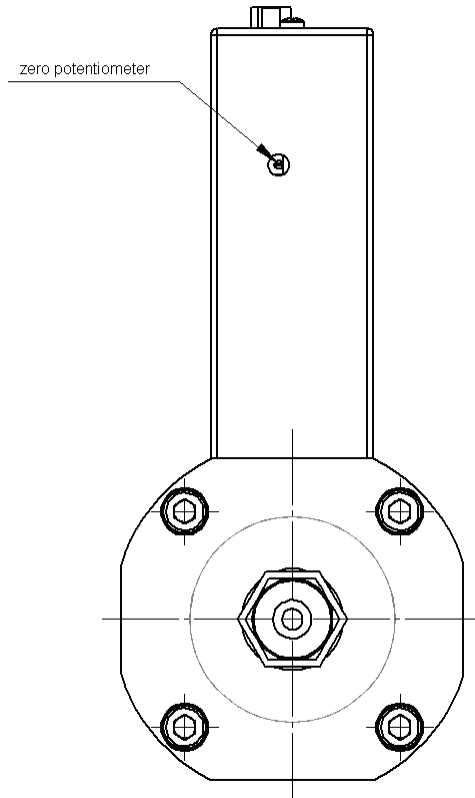

Figure 9. The Position of Potentiometer of D07-60G & D07-60GM

There is another external zero adjustment function, while MFC connected with our new zero adjustment functional D08 Flow Readout Box, it could be achieved by zero potentiometer of display panel. The important is the ranges of external zero adjustment is narrow, when there is big zero excursion happened, it should be better adjust zero from zero potentiometer of MFC.

## 5. OPERATING INSTRUCTIONS (Together with Flow Readout Box)

### 5.1 MFC Operation

#### 5.1.1 Start up (Reference to Figure 10)

The main operating should perform in the Flow Readout Box. Valve Control Switches and flow setting potentiometer are in the front of display panel, the flow setting internal or external signal control switches are on the back of panel of Readout Box. When the switch is turned on the “INT” position, the potentiometer will control flow rate; when the switch is turned on “EXT” position, the external signal will control flow rate (Please check out the details in Flow Readout Box Instruction).



Figure 10. Flow Readout Box Operating Panel

- a. When valve switch is on the position of AUTO, gas supply should be open first and then turn on the power supply, the flow rate will not be beyond 5% of presetting after flow soft-start about 20 seconds. General speaking it should be warming up around 15 minutes in case valves shut off and gas flow cut off, after stable zero movement, normal operation could begin. If there is big zero excursion, please see the reference 4.5, in the case of non-gas flow, it's better adjust zero by zero potentiometer.
- b. If Valve switch is on the position of OFF, after power supplying, gas supplying and warming-up, turn switch to AUTO position, flow rate will reach the presetting 2%(or lower) after a few seconds, which is the suggested operating method.
- c. If Valve switch is on the position of PURGE, the flow rate will reach up to the maximum value after gas and power supplying, which will have the function of air blasting to the gas circuit.
- d. If Valve switch is on the position of AUTO and presetting is not zero, open the gas after power supply, the flow rate will have a big overshoot and then rapidly reach to the stable presetting value, this kind of operation should better be avoided.
- e. The best operating sequence should be:
  1. Open the power supply;
  2. Turn the Valve switch on OFF position;
  3. Open the gas supply;
  4. Warm up for minutes to have stable zero point movement;
  5. Turn the switch on AUTO position;
  6. Set flow rate under request.This is the best way to operate without an overshooting.

## 5.1.2 PURGE

When need air blasting and cleaning bypass and tube, users could turn the switch on PURGE position, during the purging, flow rate value should reach up to times or even several decuples of the full scale flow value. If shutoff gas supplying, it could be vacuum pumping to get rid of MFC internal or upper reaches remained gas matching request. And then shut off valves, open gas supply again and turn it to AUTO position.

## 5.1.3 Readout Box & PC Connections

Please find the reference in Figure 5 and Figure 10, it should set the switch of Readout Box to the "External" and turn the switch to the position of "CONTROL", and then startup PC.

## 5.1.4 PC Connections

Please have the reference in Figure 7 and Figure 8, after MFC warming up, it could have PC startup.

## 5.1.5 Valve Control

When "OFF" wire connected to "0V", the valve will be shutoff, please find the reference in Figure 2 and Figure 5. When "ON" wire connected to "+24VDC", the valve will be turned to the top of maximum to purge position; when "OFF" wire and "ON" wire both unconnected, valve will be turned to valve control position; Please don't connect "ON" and "OFF" at the same time. when "ON" wire and "OFF" wire work at the same time, the valve will be turn to purge position.

## 5.1.6 Shut Off Operation

After shutoff power supply, flow will be cut off automatically. It should be better shut off gas supply (Turn valve switch to OFF position and close the cut-off valve of gas circuit) before power supply.

## 5.2 MFM Operation

### 5.2.1 Start Up

Please warm up for 15 minutes by power supply before MFM operating.

### 5.2.2 Zero Testing and Adjustment

Please check up zero point of MFM after its warming up (especially for the first time operating), it could have reference in 4.5, without gas supplying, which could adjust zero by zero potentiometer.

### 5.2.3 Gas Supply

After zero movement reaches stable, MFM Could have gas supply. Please pay attention to the flow rate, it should be better operate not beyond full scale range.

### 5.2.4 Shut Off

Turn off the power supply, which means MFM operating will be terminated, it could not affect the flow rate of bypass.

## 6. CAUTION

### 6.1 Medium Forbidden

The gas of using should be purified without dust, liquid and oil stain. When necessary, it should be added filter to gas circuit to make sure gas purified. If the outlet of MFC connects with liquid sources, which should be added simple directional valve of MFC outlet to avoid the liquid is reflux to the tube to destroy MFC.

### 6.2 Corrosive Gas

The materials of bypass are anti-caustic materials like 00Cr17Ni14Mo2(same as 316L stainless steel), Teflon, and Viton. When users operate in condition of without vapor, low leakage, regular cleaning and proper operating, MFC could possible control the normal corrosive gas. Using ammonia, organic solvent gas such as acetone or other strong caustic gas (like BC13 and BBr3), please informed in your order statements. Valves Dynamic sealing materials usually are Viton. There maybe leakage happened of valve port, valve sealing leakage rate will lower than 2% of full scale flow rate; when use the special caustic gas, all sealing materials should be changed relatively.

**For the cases that the MFC/MFM used with toxic, pyrophoric, flammable or corrosive gas, you should ensure that the fixing and fitting are airtight. It becomes necessary to remove the controller from the system, purge the controller thoroughly with a dry inert gas such as nitrogen, before disconnecting the gas connections. Failure to purge the controller could cause a fire or explosion resulting in death.**

### **6.3 Valves Dynamic Sealing**

The Valve of MFC is an electric-magnetic valve for adjustment, which is not a solenoid plug valve so that could not perform that kind of function. Users should better have that plug valve by themselves. Especially when users operate with caustic gas, general speaking, it should separately add one cut-off valve of MFC inlet and outlet to protect operating security. After a long period operating, if the leakage rate of MFC valve outlet is not beyond 2% F.S, it is the standard situation. Otherwise, it should be under maintaining.

### **6.4 Valves operating**

When valve is operating PURGE, which should not be directly turned to AUTO, operation should be turned the switch to OFF position and then turn it into AUTO to operating.

### **6.5 Installation Position**

Keeping installation surface horizontal while installation. Please provide the installation position when ordering the MFC. We will calibrate products according to the requirement of customers. The MFC might show the zero drift if it is not installed as the same position of calibration. Customer can adjust zero to fix it.

### **6.6 Operation Pressure Resistance**

Please be caution for the medium operating pressure of MFC, it should not be beyond the rage of specification of inlet and outlet. Especially while operating under the high-pressure situation, the big differential pressure will affect flow fail to shut off or lower adjustment. In case of using heavy flow rate of MFC, please be sure appropriately widen tube and reduce gas internal resistance, if operating differential pressure is lower than the value of request, it might could not be reach to the full scale flow rate value.

### **6.7 Calibration and Conversion**

D07 series is calibrated by nitrogen. Other gas calibrations please inform in your order statements. When the nitrogen calibration users use other gas operating, it could convert and calculate used gas flow rate by conversion factors of appendix 8.1. Which means users could multiply the readout flow rate from MFC Readout Box with the used gas corresponding conversion factors, the result will be the used gas corresponding mass flow rate of standard situation.

For example, there is 1000 SLM (N2) calibrated MFC, the flow rate is displayed 860 SLM while firedamp flowing, the conversion factors of firedamp is 0.719 from reference of appendix 9.1, the real firedamp flow rate is  $860 * 0.719 = 618$  SLM.

If users use the mixture gas, it could be calculated the conversion factors by the method which introducing in appendix 9.2.

## 6.8 D07-60G,60GM Ordering Code

D07-[t] [g,g,g] [r,r,r,r] [f,f] [s] [m] [d]

### **[t] -Type Number**

- [60G ] MFC
- [60GM]MFM

### **[g,g,g] -Gas**

Please consult SEMI52-0302

For Example:

- [ 013 ] N<sub>2</sub>
- [ 007 ] H<sub>2</sub>
- [ 000 ] Mixture gases (please consult [d] for detail)

### **[r,r,r,r] -Flow Range Full Scale**

- [300L] 300SLM
- [500L] 500SLM
- [750L] 750SLM
- [1K0L] 1000SLM
- [1K5L] 1500SLM
- [ 2K0L] 2000SLM
- [ 000C] Customer Special Request (please consult [d] for detail)

### **[f,f] -Inlet and Outlet Fittings**

- [JJ ] Compression Fitting  $\phi$  10mm (F.S.=300SLM)
- [PP] Compression Fitting 1/2"(F.S.  $\leq$ 1000SLM)
- [XX ] Customer Special fittings (please consult [d] for detail)

D07-[t] [g,g,g] [r,r,r,r] [f,f] [s] [m] [d]

**[s] -Seal Materials** ←

- [ V ] Viton
- [ N ] Neoprene

**[m] -Mounting Position** ←

- [ H ] Horizontal
- [ E ] HESD(Horizontal Edge Side Down)
- [ U ] Vertical Inlet Up
- [ D ] Vertical Inlet Down

**[d] -Description** ←

-[ ] **Default Value:**

**The letters on cover and tag: in Chinese**

**Differential Pressure: D07-60G: 300~1000SLM: (0.25~0.50) MPa**

**1500,2000SLM: (0.40~0.60) MPa**

**D07-60GM: 300~2000SLM: <0. 2MPa**

**Max Operating Pressure: 3 MPa**

**Calibration Temperature: (22±2)°C**

-[ S ] **Customer Special Requirements:**

**For Example: The letters on cover and tag: in English; Customer Special Full Scale:29SLM; The proportion of Mixture gases should be indicated: N<sub>2</sub> (60%) + CO<sub>2</sub>(40%); Customer Differential Pressure: (0.08 ~ 0.13) MPa; Customer Calibration Temperature: 40°C; D07-60G Setpoint Signal: Voltage 0~5VDC and other customer special requirements.**

**For Example: D07-60G0131K0LPPVHS**

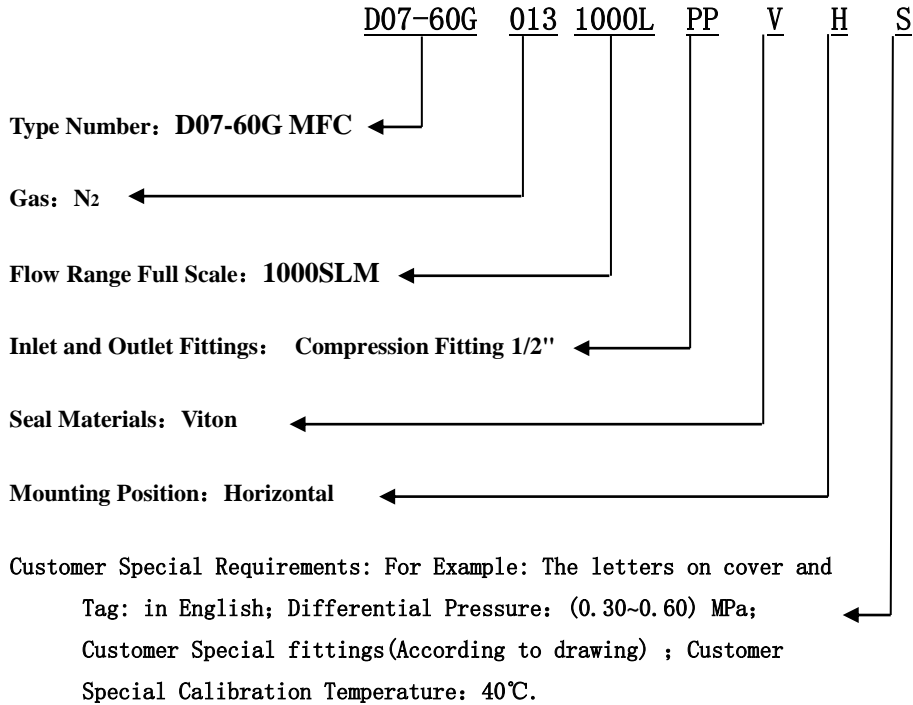



## 7. TROUBLESHOOTING

Table 3. Failure Handling

NO.	FAILURE	CAUSE	TREATMENT
1	There is no gas flow after turn on.	1.1 Gas flow is shutting off, no gas inputting	Check the gas sourcing and make it open
		1.2 Valve control switch is shutoff	Turn the switch to CONTROL or PURGE
		1.3 No setting signal	Check potentiometer or “In/Out” switch setting position
		1.4 Filter is blocked	* Change a new filter
		1.5 Valve failure	Test or *clean valve
		1.6 Circuit failure	*Repair the electric circuit
2	In case of turning on but without gas flow, the flow rate testing is error.	2.1 Zero excursion	Adjust the zeroing potentiometer
		2.2 Power supply failure	*Check Power supply voltages (24VDC)
		2.3 Sensor failure	*Replace the new sensor
		2.4 Amplifier or other circuits failure	*Replace amplifier or repair circuit
3	In case of valve shutting off, there is still heavy flow rate passing.	3.1 Over- load pressure of input outlet, the differential pressure between inlet and outlet is beyond rating.	Reduce the inlet operating pressure to decrease differential pressure.
		3.2 Pollution of valve	*Clean valve and replace seal ring
		3.3 Valve failure	*Re-adjust solenoid control valve
4	The flow rate display could not reach to full scale flow rate value.	4.1 Pressure is lower than the rating	Heighten the inlet pressure
		4.2 Block of bypass	*Clean bypass
		4.3 Setting voltage is less than5.00V	*Check the setting Voltage
		4.4 Others trouble	*Repair circuit etc.

Continue To Table 3. Failure Handling

NO.	FAILURE	CAUSE	TREATMENT
5	Fluctuant flow rate	5.1 Inlet pressure is too low or instable	Heighten inlet pressure
		5.2. High internal gas resistance	Lessen internal resistance (The heavy gas flow should have big valve open, widen tube to parallel connecting gas bottles to improve gas supply capacity.)
		5.3 Circuit or valve failure	*Repair and adjust
6	Disturbed by high frequency power sourcing	6.1 Earth wire and zero wire connecting of power supply is error	Check the earth wire connection, should be one port connection.
		6.2 Signal reference port connecting problem	Check signal connecting wire.
		6.3 Inter space disturbing	
7	Flow display is inaccurate	7.1 The range or unit of Display is not matching to controller.	*Re-adjust Display
		7.2 Bypass is polluted to cause the flow rate excursion.	*Clean MFC and re-calibrate it
		7.3 Zero excursion happened to be instable.	* Change sensor and repair circuit
8	There is still flow passing while zero setting.	8.1 Valves leakage	*Repair solenoid control valve
		8.2 Zero point is moving less than 0	Adjust zero
9	The heavy flow is passing but no outputting display	9.1 Block of sensor	*Repair and replace the new sensor Should add filter to block gas dust. Using special gas should be sure of good tube sealing and gas dryness.
		9.2 Circuit failure	*Repair circuit
10	Without gas flow, Zero is fluctuate or excursion happened.	10.1 Sensor failure	*Replace a new sensor

**Attention:**

\* Mark indicates that reparation and adjustment must be dealt under specialist advices .

## 8. WARRANTY & SERVICE

### 8.1 Product Warranty

- a. Our products are guaranteed within 1 years warranty against defects in materials and workmanship if used in accordance with specifications and not subject to physical damage, contamination, alteration or retrofit.
- b. Buyers undertake to check and inspect the goods and to notify SevenStar of shipment incidents by fax, phone or e-mail as soon as possible after receipting the goods.
- c. During the warranty period, products must only be repaired by Sevenstar or authorized SevenStar service centers; otherwise, the SevenStar product warranty will be invalidated.
- d. Repairs will be performed free of charge during the one-year warranty period. If MFCs/MFMs are out of warranty, SevenStar will notify the owner of replacement or repair costs before proceeding. Factory service and repairs are guaranteed 90 days. The warranty excludes consumable materials and wear parts (in teflon, viton, etc.).
- e. No MFC/MFM used with dangerous gas will be accepted for repair or warranty without a decontamination and purge certificate.

### 8.2 Specific warranty requirements are as follows :

- a. Gas must be clean and particle-free, which means a filter( <30 $\mu$ ) must be fitted in the gas line upstream of the MFC/MFM.
- b. Gas must comply with the pressure specifications, and never exceed the rated value.
- c. Process gas should be in line with the seal materials chosen in the order, especially in case of corrosive gas. We shall not be responsible for any damage caused by changing process gas or choosing the wrong seal materials in order.
- d. Electrical connection requirements are as follows: The system must be wired carefully: non-observance of the pin out may irreversibly damage the electronic board inside the products. If user self scheme power supply of MFCs, a stable and anti-jamming power supply is required, with ripple below 5mV.
- e. Gas connections: the fittings must be handled carefully. We guarantee that all fittings have been individually inspected and are scratch-free.
- f. The MFC/MFM must not be dismounted: the MFC/MFM warranty will be invalidated if the seal between the MFC/MFM block and cover is torn.

### 8.3 Service

Our product engineer will help you with issues related to operation, calibration, installation, process specification, gas convention, etc. And we also provide you with technology support& maintenances, and products operation training.

Please visit [www.mfcsevenstar.cn](http://www.mfcsevenstar.cn) for relevant information and the locations of our service centers.

## 9. APPENDIX

### 9.1 Mass Flow Conversion Factors

Table 4. Conversion Factors

GAS	GAS CODE (SEMIE52-0302)	HEAT ( Cal/g °C )	$\rho$ (g/l 0°C)	Factors
Air	008	0.2400	1.2930	1.006
Ar	004	0.1250	1.7837	1.415
AsH <sub>3</sub>	035	0.1168	3.4780	0.673
BBr <sub>3</sub>	079	0.0647	11.1800	0.378
BCl <sub>3</sub>	070	0.1217	5.2270	0.430
BF <sub>3</sub>	048	0.1779	3.0250	0.508
B <sub>2</sub> H <sub>6</sub>	058	0.5020	1.2350	0.441
CCl <sub>4</sub>	101	0.1297	6.8600	0.307
CF <sub>4</sub>	063	0.1659	3.9636	0.420
CH <sub>4</sub>	028	0.5318	0.7150	0.719
C <sub>2</sub> H <sub>2</sub>	042	0.4049	1.1620	0.581
C <sub>2</sub> H <sub>4</sub>	038	0.3658	1.2510	0.598
C <sub>2</sub> H <sub>6</sub>	054	0.4241	1.3420	0.481
C <sub>3</sub> H <sub>4</sub>	068	0.3633	1.7870	0.421
C <sub>3</sub> H <sub>6</sub>	069	0.3659	1.8770	0.398
C <sub>3</sub> H <sub>8</sub>	089	0.3990	1.9670	0.348
C <sub>4</sub> H <sub>6</sub>	093	0.3515	2.4130	0.322
C <sub>4</sub> H <sub>8</sub>	104	0.3723	2.5030	0.294
C <sub>4</sub> H <sub>10</sub>	111	0.4130	2.5930	0.255
C <sub>5</sub> H <sub>12</sub>	240	0.3916	3.2190	0.217
CH <sub>3</sub> OH	176	0.3277	1.4300	0.584
C <sub>2</sub> H <sub>6</sub> O	136	0.3398	2.0550	0.392
C <sub>2</sub> H <sub>3</sub> Cl <sub>3</sub>	112	0.1654	5.9500	0.278
CO	009	0.2488	1.2500	1.000
CO <sub>2</sub>	025	0.2017	1.9640	0.737
C <sub>2</sub> N <sub>2</sub>	059	0.2608	2.3220	0.452
Cl <sub>2</sub>	019	0.1145	3.1630	0.858
D <sub>2</sub>	014	1.7325	0.1798	0.998
F <sub>2</sub>	018	0.1970	1.6950	0.931
GeCl <sub>4</sub>	113	0.1072	9.5650	0.267

Continue To Table 4. Conversion Factors

GAS	GAS CODE (SEMIE52-0302)	HEAT ( Cal/g °C )	$\rho$ (g/l 0°C)	Factors
GeH <sub>4</sub>	043	0.1405	3.4180	0.569
H <sub>2</sub>	007	3.4224	0.0899	1.010
HBr	010	0.0861	3.6100	1.000
HCl	011	0.1911	1.6270	1.000
HF	012	0.3482	0.8930	1.000
HI	017	0.0545	5.707	0.999
H <sub>2</sub> S	022	0.2278	1.5200	0.844
He	001	1.2418	0.1786	1.415
Kr	005	0.0593	3.7390	1.415
N <sub>2</sub>	013	0.2486	1.2500	1.000
Ne	002	0.2464	0.9000	1.415
NH <sub>3</sub>	029	0.5005	0.7600	0.719
NO	016	0.2378	1.3390	0.976
NO <sub>2</sub>	026	0.1923	2.0520	0.741
N <sub>2</sub> O	027	0.2098	1.9640	0.709
O <sub>2</sub>	015	0.2196	1.4270	0.992
PCl <sub>3</sub>	193	0.1247	6.1270	0.358
PH <sub>3</sub>	031	0.2610	1.5170	0.691
PF <sub>5</sub>	143	0.1611	5.6200	0.302
POCl <sub>3</sub>	102	0.1324	6.8450	0.302
SiCl <sub>4</sub>	108	0.1270	7.5847	0.284
SiF <sub>4</sub>	088	0.1692	4.6430	0.348
SiH <sub>4</sub>	039	0.3189	1.4330	0.599
SiH <sub>2</sub> Cl <sub>2</sub>	067	0.1472	4.5060	0.412
SiHCl <sub>3</sub>	147	0.1332	6.0430	0.340
SF <sub>6</sub>	110	0.1588	6.5160	0.264
SO <sub>2</sub>	032	0.14890	2.8580	0.687
TiCl <sub>4</sub>	114	0.1572	8.4650	0.206
WF <sub>6</sub>	121	0.0956	13.2900	0.215
Xe	006	0.0379	5.8580	1.415

## 9.2 Conversion Factors Instruction

MFC and MFM are standard calibrated by N<sub>2</sub> while it's out of factory. Other gas calibrations can be approximated by converting of conversion factors of our instruction. While using other gas operating:

One single gas: The conversion factors could find out in the users specification instruction.

A mixture of two or more gases: Assume there is “n” sorts of gases, could calculate the conversion factors C by the following formula:

Basic Formula:  $C = 0.3106 N / \rho (C_p)$

$\rho$  — Density of the gas

$C_p$  — Specific heat of the gas

N — Structure factors of gas-molecule (See Table 6.)

Table 6. Gas-Molecule Composing factors

COMPOSITION	EXAMPLE		N VALUE
Single atom numerator	Ar	He	1.01
Double atom numerator	CO	N <sub>2</sub>	1.00
Tree atom numerator	CO <sub>2</sub>	NO <sub>2</sub>	0.94
Multi-atom numerator	NH <sub>3</sub>	C <sub>4</sub> H <sub>8</sub>	0.88

For mixture gases:  $N = N_1 (\omega_1/\omega_T) + N_2 (\omega_2/\omega_T) + \dots + N_n (\omega_n/\omega_T)$

Then:

$$C = \frac{0.3106 [N_1 (\omega_1/\omega_T) + N_2 (\omega_2/\omega_T) + \dots + N_n (\omega_n/\omega_T)]}{\rho_1 C_{p1} (\omega_1/\omega_T) + \rho_2 C_{p2} (\omega_2/\omega_T) + \dots + \rho_n C_{pn} (\omega_n/\omega_T)}$$

$\omega_1 \dots \omega_n$  — The flow of single gas

$\omega_T$  — The flow of mixture gas

$\rho_1 \dots \rho_n$  — The density of single gas

$CP_1 \dots CP_n$  — Specific heat of the single gas

$N_1 \dots N_n$  — Structure factors of gas-molecule (See Table 6.)

### Attention

- 1) **Standard: Temperature 273.15K (0 °C); Air Pressure— 101325 Pa (760mm Hg)**
- 2) **Please feel free to contact us if the request gas conversion factors could not be found in our appendix.**



Beijing Sevenstar Flow Co., Ltd.

## D07 Series

# Mass Flow Controller

Beijing Sevenstar Flow Co., Ltd.

---

Address: No.1 Jiuxianqiao East Rd., Chaoyang District, Beijing, China  
P.O.BOX 3#741, Beijing, China  
Post code: 100015  
Tel: (+86)-10-64361831 ext. 8527  
Fax: (+86)-10-64362923  
Homepage: [www.mfcsevenstar.cn](http://www.mfcsevenstar.cn)  
E-Mail: [mfcsales@sevenstar.com.cn](mailto:mfcsales@sevenstar.com.cn)

---

Shanghai Office: Rm.722 Bldg.29, No.368, Zhangjiang Rd, Pudong New Area,  
Shanghai, China  
Tel: (+86)-21-63532370  
Fax: (+86)-21-63533265

---

Shenzhen Office: Room 712, Section B, Qiche Tower, No.45 Zhenhua Road,  
Futian District, Shenzhen, China  
Zip code: 518031  
Tel: (+86)-755-88290258  
Fax: (+86)-755-88294770

---

\*Description may be changed following improvements to product. The information contained in this document is subject to change without notice

\*If there is any mistake in this uses manual, please feel free to contact us.

\*©2010 Beijing Sevenstar Flow Co.,Ltd.

All rights reserved.