

CS230A MFC/MFM

User's Manual



北京七星华创流量计有限公司
Beijing Sevenstar Flow Co., Ltd.
Version March, 2017

Contents

SECTION 1 INTRODUCTION		
1.1 Declaration	1	
1.2 Attention	2	
1.3 The notice of safety	2	
1.4 General	3	
1.5 Specification	5	
1.6 Calibration features	6	
SECTION 2 INSTALLATION		
2.1 General	7	
2.2 Unpacking	7	
2.3 Mechanical Installation	7	
2.3.1 General.....	7	
2.3.2 Installation	13	
2.3.2.1 1/2 VCR Connection.....	13	
2.3.2.2. Two-ferrule (Compression Fitting) Connection.....	13	
2.4 Electrical Installation	14	
2.5 Checking Before Operation	19	
SECTION 3 FUNCTIONS		
3.1 General	20	
3.2 Control Mode	20	
3.3 Zero	20	
3.4 Soft-Start	21	
3.5 Delay	21	
3.6 Valve Command Mode	21	
3.7 Valve Type	21	
3.8 Multi-Gas and Multi-Flow	21	
3.9 Total Flow Accumulator	22	
3.10 Alarm	22	
3.11 LED	23	
SECTION 4 MAINTENANCE		
4.1 General	23	
4.2 Caution	23	
SECTION 5 TROUBLESHOOTING		
5.1 Initial check	24	
5.2 Troubleshooting	24	
SECTION 6 WARRANTY AND SERVICES		
6.1 Guarantee of Sevenstar	25	
6.2 Product Warranty	26	
6.3 Services	27	
6.4 Disclaimer	28	
APPENDIX I	29	
APPENDIX II	31	

MFC/MFM

User's Manual

SECTION 1 INTRODUCTION

1.1 Declaration

The copy right of *The user's manual of mass flow controller and mass flow meter* is subjected to Beijing Sevenstar Electronics Co., Ltd (following abbr. Sevenstar), which is not allowed to duplicate, store and distribute any part of this manual in mean of electric, mechanical, photocopy, recording or other way without permission of Sevenstar. This manual is not assured that there is no mistake and missing in which have been corrected strictly, and the publisher is under no obligation to the mistake or missing, meanwhile the publisher is not in charge of any loss that this manual leads to.

1.2 Attention

Dear customer, thanks for using CS mass flow controller and mass flow meter. This manual describes in detail important issues about correct and safe operations of the product.

User of the product should read and comprehend this manual and pay attention to the text with labels  and notices.

Sevenstar assumes no liability for the customer's failure to comply with this manual. This manual is necessary for your installation and maintenance, please keep it carefully.

1.3 The notice of safety

Please pay attention to the below notices when reading this manual. We are not responsible for any result without abiding by the below notices.

a) Do not replace any components or disassemble instrument.

Do not replace any components, or disassemble the instrument without any authorized and make sure that the label or/and seal of product is not removed when returning for reworking, recalibration and maintenance.

b) Please contact professional for technical service.

Do not replace any components. Any technical support is provided by professional who must be authorized by Sevenstar.

c) Please pay more attention to use dangerous gas.

Instrument should be purged completely and keep safety if dangerous gas is used. Meanwhile make sure that moist gas must not react with material of seal and instrument.

d) Please pay attention to purging instrument.

The whole system should be purged by dry gas after and before the instrument is installed.

e) Please abide by proper steps of purging.

Product should be purged and handled with gloves.

f) Do not use the instrument in explosive environment.

Do not use the instrument in explosive environment, unless the safety certificate is available.

g) Please use proper fittings and keep the rules.

All fittings of instrument must be matched according to the listing in manual. Please read manual carefully before screwing tightly.

h) Please do leakage check.

Please check carefully all of vacuum parts and make sure that there is not leakage in the system.

i) Please make sure that instrument is working under safe pressure.

Please make sure that the pressure of inlet gas is less than maximum working pressure (referring to maximum working pressure in manual).

j) Please keep the whole system away from pollution.

When system running, do not use polluting gas, such as particle of dust, dirt, fibre, glass or scrap iron.

k) Please do warm-up instrument before working.

Please do warm-up instrument, especially in using dangerous gas. Please close valve completely to make sure that there is not error flow.

1.4 General

Mass flow controller (MFC) accurately measures and controls mass flow rates, which is widely applied in the fields as: semiconductor and IC fabrication, special materials science, chemical industry, petrolic industry, pharmaceutical industry, environmental protecting and vacuum system researching, etc.. The typical applications include: microelectronic process equipment such as diffusion, oxidation, epitaxy, CVD, plasma etching, sputtering, ion implantation, vacuum deposition equipment, optical fiber melting, micro-reaction equipment, mixing & matching gas system, capillary flow control system, gas chromatograph and other analytical instruments.

The CS230A MFC/MFM are a latest generation MFC for use in semiconductor

applications and demanding industrial uses where its high accuracy and flexibility in interfacing are required.

The CS230A MFC/MFM incorporate a dual interface, voltage and current as well as RS-485 digital interfaces. It is possible to operate the instrument completely digitally or it can be operated in analog mode with digital monitoring. CS230A series have wide range of power supply(available for $\pm 8 \sim \pm 16$ VDC or $+14 \sim +28$ VDC).

In addition, autoAlarm, change of operating gas and range available through the digital interface. Customer Secondary Development of control and sample software is available through the open protocol.

CS230A MFC default setting:

MAC address: 32;

RS485 baud rate: 19200;

Control mold: 0-5V analog signal control.

1.5 Specification

Type	CS230A	
Full scale range (N ₂)	(50,100,150,200,250,300) SLM	
Accuracy	±1.0% S.P. (≥35% F.S.)	±0.35% F.S. (<35% F.S.)
Linearity	±0.5% F.S.	
Repeatability	±0.2% F.S.	
Response Time	≤2sec	
Valve Rest Position	Normally Closed or Normally Open	No Valve
Differential Pressure	0.15~0.35MPa 50SLM≤Flow(N ₂)<150SLM 0.20~0.35MPa 150SLM≤Flow(N ₂)≤250SLM 0.25~0.40MPa 250SLM<Flow(N ₂)≤300SLM	50~100SLM: <0.02MPa > 100SLM: <0.05MPa
Temperature Coefficient	Zero: ≤ ±0.05% F.S./°C; Span: ≤ ±0.1% F.S./°C	
Max Pressure	3MPa (435psig)	
Zero Drift	<0.6%F.S. per year without autozero	
Leak integrity	1×10 ⁻⁹ atm-cc / sec He	
Wetted Materials	Viton; Neoprene	
Operation Temperature	(5~45) °C	
Input Signal	Digital: RS485 or DeviceNet™ Analog:(0~5)VDC or (4~20)mA	N/A
Output Signal	Digital: RS485 or DeviceNet™ Analog:(0~5)VDC or (4~20)mA	
Power Supply	±8 ~ ±16 VDC or +14 ~ +28 VDC(400mA)	
Electronic Connector	9 pin male sub-D ; 15 pin male sub-D ; DeviceNet™ male	
Fittings	Compression Fittingφ6; Compression Fitting1/4 ʹ; (available to Flow(N ₂)≤60SLM) Compression Fittingφ8mm (available to Flow(N ₂)≤ 200SLM) Compression Fitting φ10mm; Compression Fitting 3/8 ʹ; Compression Fitting 1/2 ʹ; VCR 1/2 ʹ;	
Weight	2.6kg	1.5kg

Notes

MFC/MFM is calibrated by N₂ as a standard gas.

Units: SCCM (Standard cubic centimeter/min);

SLM (Standard liter/min)

Standard situation: Temperature 273.15K (0 °C); Air pressure 101325 Pa (760mm Hg)

For Sevenstar MFC/MFM, the unit of SCCM is identical to “mL/min, 0 °C ,1atm”, and the unit of SLM is identical to “L/min, 0 °C ,1atm”.

F.S: Full Scale

1.6 Calibration Features

Normally, the MFC are calibrated close to customer's requirement (the requirement should be accorded with the specification). Without customer's information, the MFC are calibrated under standard conditions.

1.6.1 Standard conditions

Without special conditions specified by the customer, the MFC is calibrated under the following standard conditions:

Pressure Outlet: Atmospheric.

Normally gas mass flow rate is transferred to gas volume flow rate at standard state.

Mass flow rate unit:

SCCM---standard cubic centimeter per minute.

SLM-----standard liter per minute.

Standard state: Temperature — 0 °C (273.15K)

Pressure — 101325Pa (760mmHg)

At standard state, the gas density will be constant. The multiplication of density and volume flow rate is equal to the mass flow rate. Therefore at the standard state, the volume flow rate can represent mass flow rate.

The standard mounting position is horizontal, And other positions such as vertical(inlet up or down), flatwise or customized position are optional. The mounting position should be specified by the customer to ensure the best accuracy.

1.6.2 Manufacturing Environment

The MFC are assembled in a class 100 clean room, calibrated, packaged and controlled in class 1000 environment. The temperature is $22 \pm 2^{\circ}\text{C}$.

1.6.3 Precision Adjustment

Each MFC is accurately controlled for 24 hours after manufacturing on a different

calibration bench. The accuracy, the dynamic response, the stability to pressure variations is double checked, only qualified product available for sale.

SECTION 2 INSTALLATION

2.1 General

WARNING: Toxic, corrosive or explosive gases must be handled with extreme care. After installing the MFC, the system should be thoroughly checked to ensure it is leak-free. Purge the MFC with a dry inert gas for one hour before using corrosive gases.

IMPORTANT: When installing the MFC, ensure that the arrow on the back of the unit in the same direction as the gas flow.

2.2 Unpacking

The CS230A MFC/MFM are assembled, calibrated and clean packaged under clean room conditions. These series products are packaged with two separately sealed plastic bags. The outside is common plastic bag, the inside is clean bag. The outside bag should be removed in the entrance to the clean room. In order to minimize the contamination, the second clean bag should be removed in the clean room when MFC installed in the system.

2.3 Mechanical Installation

2.3.1 General

Most applications will require a positive shutoff valve in line with the MFC. Pressurized gas trapped between the two devices can cause purge effects, and consideration must be given to the sitting of the shutoff valve (upstream or downstream) in relation to the process sequencing. It is recommended that you install an in-line filter upstream to the controller in order to prevent MFC from contamination.

CS230A should be mounted in the position accord with the requirement in the purchase order. The gas should be clean and dry. The mounting should be free from shock

or vibration. The pictures of the MFC product are shown in figure2-1, the dimensions of the MFC product are shown in figure2-2 and figure2-4. Different fittings (Compression Fitting ϕ 6; Compression Fitting ϕ 8; Compression Fitting ϕ 10; Compression Fitting ϕ 12; Compression Fitting 1/4; Compression Fitting 3/8; Compression Fitting 1/2; VCR 1/2 Male) are optional for customer, The length of the product L are shown in Table2-1 and Table2-3. The dimensions of the MFM product are shown in figure2-3 and figure2-5. Different fittings (Compression Fitting ϕ 6; Compression Fitting ϕ 8; Compression Fitting ϕ 10; Compression Fitting ϕ 12; Compression Fitting 1/4; Compression Fitting 3/8; Compression Fitting 1/2; VCR 1/2 Male) are optional for customer, The length of the product L are shown in Table2-2 and Table2-4. Do not remove the protective end caps of the fittings until installation.



Figure 2-1 CS230A MFC/MFM

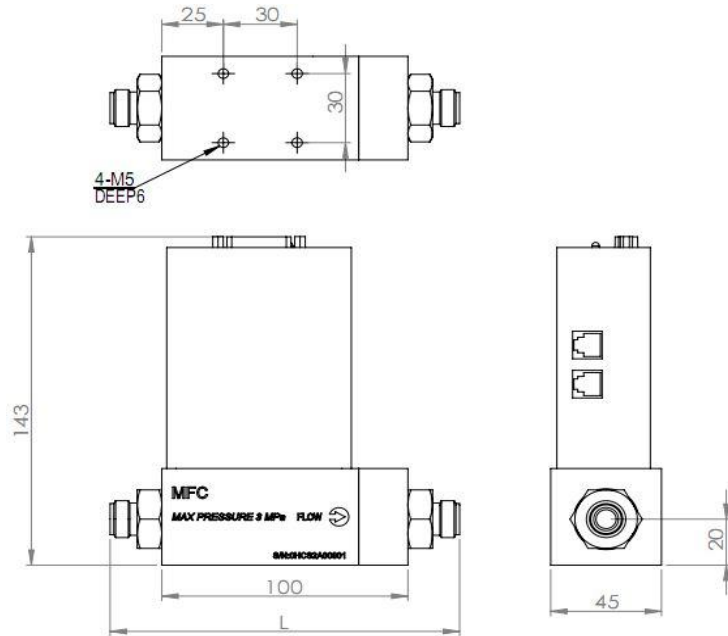

Figure 2-3 Product dimensions

Length	Fitting	Compression Fitting ϕ 6; Compression Fitting ϕ 8 Compression Fitting ϕ 10; Compression Fitting12; Compression Fitting1/4;Compression Fitting3/8; Compression Fitting1/2;	VCR1/2" M
	L (mm)	142	159

Table 2-2 The length of the product with different fittings

Attention

The height (which is showing in figure 2-3) of 143mm are height without electric connectors of cable. It should be added around 50mm more after adding the electric connector.

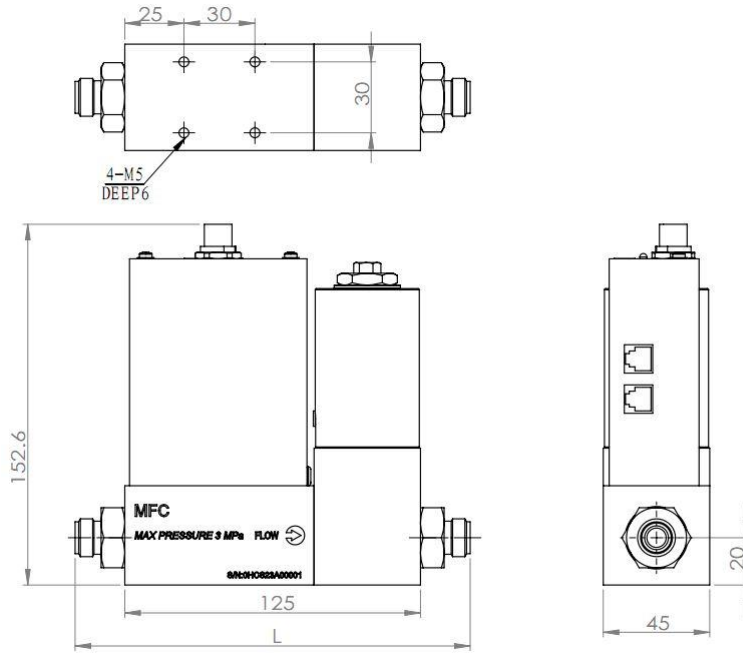

Figure 2-4 Product dimensions

Length	Fitting	Compression Fitting ϕ 6; Compression Fitting ϕ 8 Compression Fitting ϕ 10; Compression Fitting ϕ 12; Compression Fitting1/4;Compression Fitting3/8; Compression Fitting1/2;	VCR1/2" M
L (mm)		167	184

Table 2-3 The length of the product with different fittings

2.3.2 Installation

Place MFC according to the flow direction.

2.3.2.1 1/2VCR Connection

Refer to figure 2-6 and figure 2-7. Check the gland to gland space, including the gaskets. Remove the plastic gland protector caps. When using loose VCR original style gaskets, inserting the gasket into the female nut. For VCR retainer gaskets, snap the gasket onto the male coupling. Tighten the nuts finger tight. Scribe both nut and body in order to mark the position of the nut. While holding the body with a wrench, tighten the nut: 1/8 turn past finger tight for 316L stainless steel and nickel gaskets.

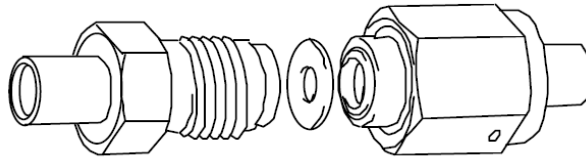

Figure 2-6 VCR original style gasket

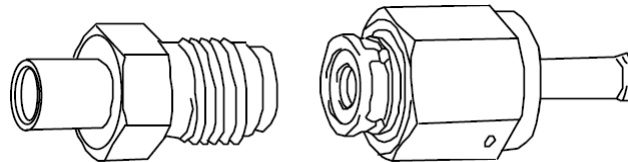

Figure 2-7 VCR retainer gasket

2.3.2.2 Two-ferrule (Compression Fitting) Connection

Refer to figure 2-8. Check the gland to gland space. Remove the gland protector caps. Insert the tubing to the shoulder inside the fitting, and check that the ferrules are positioned as shown in figure 2-8. Tighten the nuts finger tight. Use two spanners, one spanner locking the fitting stable, wrench another one to tighten in 1.25 turns to prove it's not blow-by after

installing the front ferrule, back ferrule and nut.

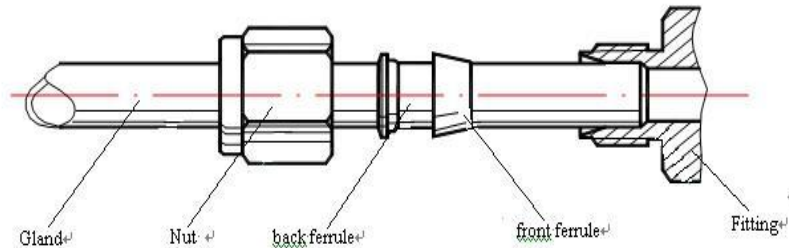

Figure 2-8 Compression Fitting Connector Installation

Attention :

When installing the fitting, you should manually use spanner to wrench it tighten by 1/2 turn pulling up, (imported Compression Fitting should use spanner to be tighten in 1,25 turns) to prove its not blow-by after your installing the front ferrule 、 back ferrule and nut. Please note you should use two spanners to operating, one spanner for locking the fitting stable and another one for revolving the nut. Especially when you dismantle the tube, you should operate by the two spanners otherwise fitting will become flexible which will affect its airproof function.

2.4 Electrical Installation

2.4.1 General

With simple switching power supply, CS230A MFC/MFM are available for ± 8 to ± 16 VDC (dual-ending) and +14 to +28 VDC (single-ending). Customer can choose as need.

Customer can choose 9 pin male Sub-D or 15 pin male sub-D connector. 9 pin male Sub-D connector is the SEMI Standard compatible, only 0-5V analog signal control and output available. 15 pin male sub-D connector, both 4-20mA and 0-5V analog signal control and output available.

CS230A MFC/MFM can communicate with PC via RS485 or DeviceNet.

2.4.2 Connections

The 9 pin male Sub-D connector, 15 pin male sub-D connector, RS485 connector ,DeviceNet connector and RS232-RS485 connector are shown in figure2-9, figure2-10 , figure 2-11 ,figure 2-12 and figure2-13.

Attention ⚠:

The 0~5V Setpoint Input, the 4~20mA Setpoint Input and the valve Over-ride are not available for CS230A MFM. That means pin1 and pin6 of D-sub 9 in figure2-9 and pin1, pin7, pin8 and pin12 of D-sub 15 in figure2-10 are not available.

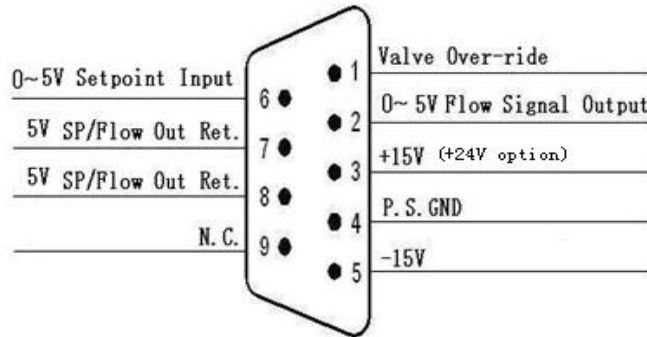

Figure 2-9 9 pin male D-sub connector

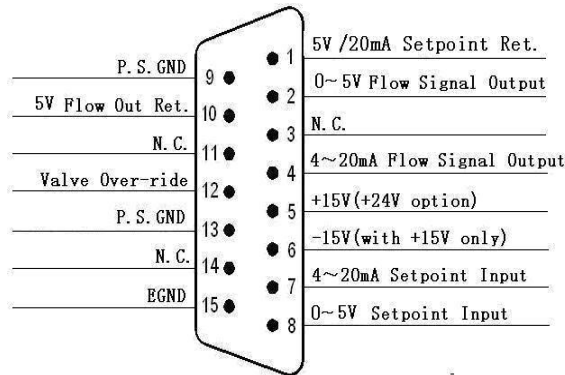

Figure 2-10 15 pin male D-sub connector

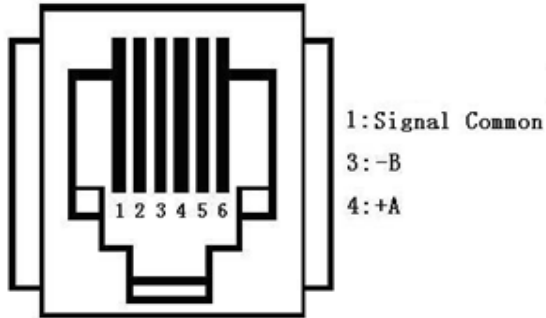

Figure 2-11 RS485 connector

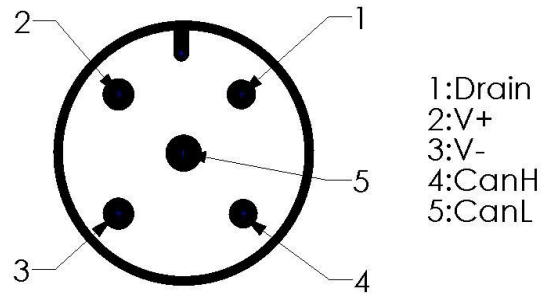

Figure 2-12 DeviceNet connector

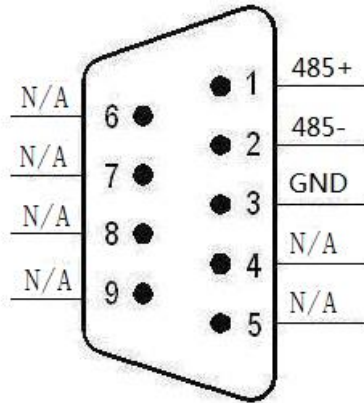

Figure 2-13 RS232-RS485 connector

2.4.3 Table of Selecting Type of Cable and its Illustration of Connection

	D08- 2B/3B/4B 2E/3E/4E	D08- 1/2/4 2F/3F/4F D08-1F/1FM/1FS/8C/8CM/1G/1GM	Input ±15V	Input +24V	To Serial of PC	To USB of Computer
MFC (DB15 Pin)	QCX-19/ QCX-P19 QCX-48	QCX-17/QCX-P17 QCX-46	QCX-41	QCX-43	QCX-34	QCX-50
MFC (DB9 pin)	QCX-20/ QCX-P20 QCX-49	QCX-18/QCX-P18 QCX-47	QCX-42		QCX-34	QCX-50

Table 2-5 Table of Selecting Type of Cable

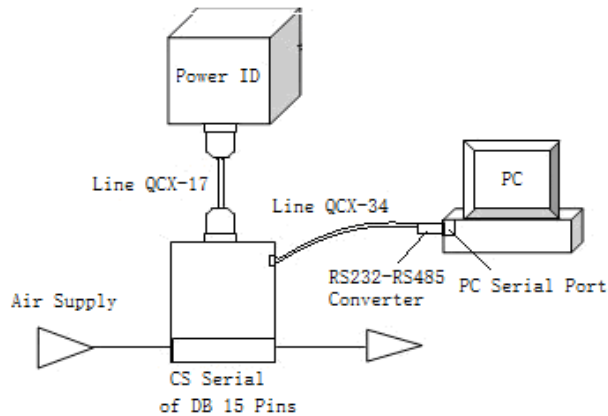

Figure 2-14 CS Product and Illustration of Connecting Power D08-1D/1F

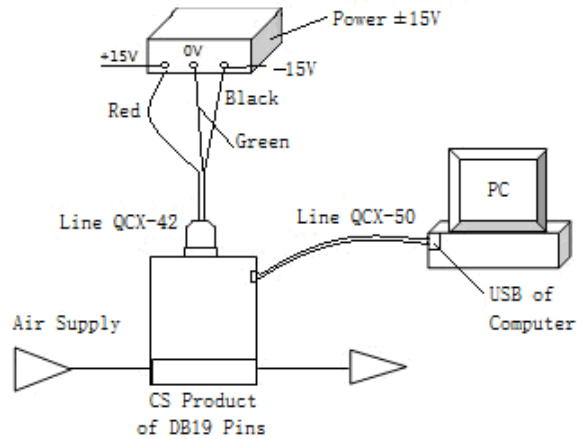

Figure 2-15 CS Product and Illustration of Connecting Power

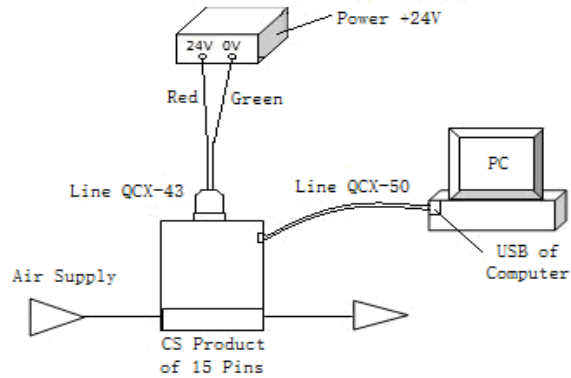

Figure 2-16 CS Product and Illustration of Connecting Power

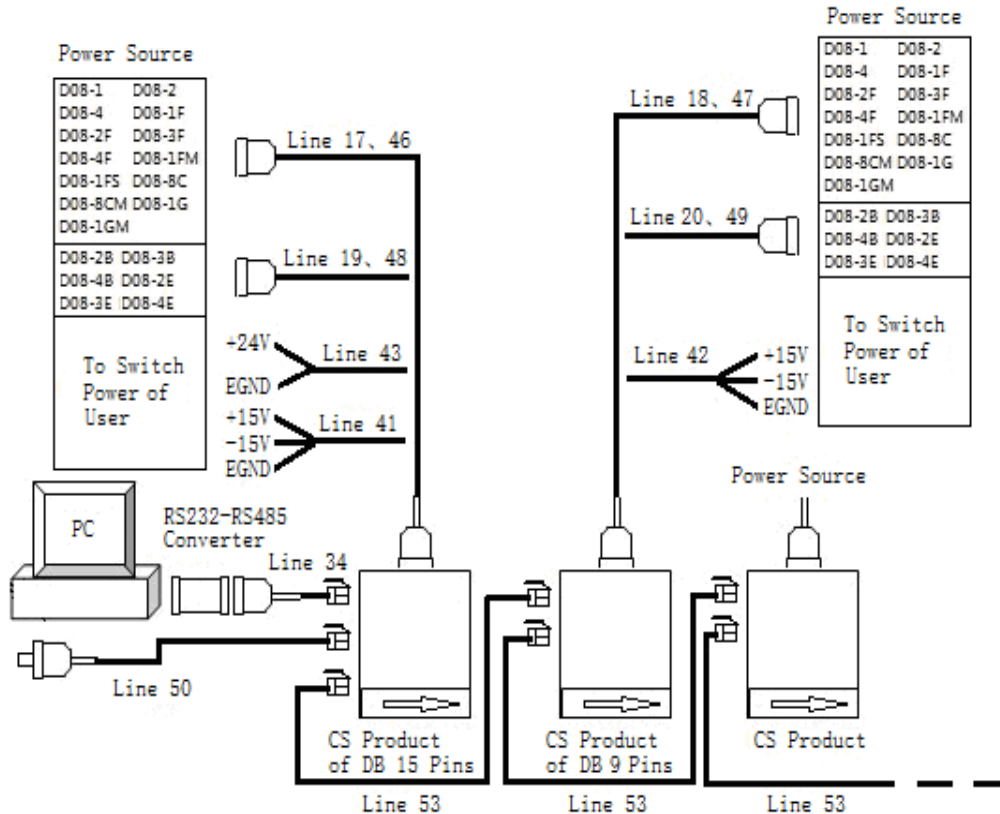

Figure 2-17 Illustration of Connecting CS Product

Sevenstar manufactures all standard cables, RS485 adaptor, customized cables and some accessories. For more details, contact Sevenstar or its local agent.

2.5 Checking Before Operation

Before operating the MFC the following checks should be completed:

- 2.5.1 Check that tubing is leak free.
- 2.5.2 Check the process sequence and proper function of all other gas components involved.
- 2.5.3 Check the voltage of command signals and power supply to the MFC/MFM.
- 2.5.4 Check that the appropriate type of gas is being supplied at the rated pressure.
- 2.5.5 Allow the MFC to warm up for 20 minutes, and then check the zero level output.
- 2.5.6 Use dry inert gas for test runs.
- 2.5.7 Prior to using the MFC for extremely corrosive gases, purge MFC with a dry inert gas for one hour.

SECTION3 FUNCTIONS

3.1 General

Based on new sensor driver technology, zero balance technology and VCP technology, CS230A MFC/MFM presents high performance and reliability. And more digital functions are developed in CS230A products.

3.2 Control Mode

CS230A MFC/MFM are available for digital, 0-5V voltage and 4-20mA current control mode and output. When customer chooses one of the three control modes, the others will be screened. The analog output will be available at all times. The flow output of the CS230A MFC/MFM will be available through the RS485 interface, even in the analog control mode. The setting of the CS230A MFC/MFM can be provided to the MFC through one of three sources, in digital or analog mode.

Please refer to “Digital MFC Communication User Manual” for more details.

3.3 Zero

The Zero function can be commanded through the digital interface or zero-button. Before zero MFC, please make sure that no gas flow through MFC. Then zero MFC by the

digital interface or zero-button. The zero-button must be pressed continuously for 0.5 seconds in order to start zero process. The green LED will blink during the zero process. After zero finished, the green LED will be on constantly.

3.4 Soft-Start

The CS230A MFC/MFM support soft-start function. Soft-start allows customer change the setting of MFC with definite rate. Please refer to “Digital MFC Communication User Manual ” for more details.

3.5 Delay

Delay is used to postpone the start of flow from zero flow to the received set-point. It is programmed in millisecond but the MFC internally rounds up any value to 100ms. For example, when the delay value is 200, MFC will delay 200ms then receiving the operate command. When the set point is less than the min control rate, the valve will shut off, and when larger than the min control rate, MFC will start after the set delay time.

Special default: Values from 1 to 49 ms will be programmed as 100ms. Delay applies to digital and analog set-points.

3.6 Valve Command Mode

CS230A MFC/MFM are available for valve-close or valve-open by input digital signal or analog voltage directly. The Valve Command Mode is used to select one of three ways to interpret the analog signal of Valve Command. Please refer to “Digital MFC Communication User Manual” for more details.

3.7 Valve Type

CS230A MFC/MFM are normally closed(NC) type valve. the “NC” type valve is closed and gas can not flow through. Please mention the valve type when you order the MFC.

3.8 Multi-Gas and Multi-Flow

The multi-gas and multi-range technology has been developed in the CS230A series

MFC/MFM. Customer can change gas convert factor, full scale of MFC via digital interface. Full scale of CS230A series MFC/MFM can be re-ranged from 30% to 110%F.S. For example, an MFC with 200SLM full scale , the new full scale can be re-ranged between from 60SLM to 220SLM.

CS230A MFC/MFM support customer offset by the target null value. The target null value is a customer-programmed constant used to offset the flow output independently of all other sensor offset constants, including the zero process. For example, set Target Null Value: -20%F.S, then when no flow through MFC/MFM, the reading is -20%F.S, with gas flow 20%F.S through MFC/MFM, the reading is 0%F.S。 Offset range is from -100%F.S to100%F.S。

Please refer to “Digital MFC Communication User Manual” for more details.

3.9 Total Flow Accumulator

The Total Flow accumulator will record the amount of gas (in SL) that has been delivered by CS230A MFC/MFM. The amount of purge will not be accumulated in the total flow amount. For example, the total reading is 3000, means the amount of gas delivered by MFC is 3000SL

Please refer to “Digital MFC Communication User Manual” for more details.

3.10 Alarm

The CS230A MFC/MFM will monitor and store certain abnormal conditions as described below. These conditions can be read and reset from the RS485 interface. Provisions will be made for masking (disabling) the alarms or warnings on an individual basis.

Warning and Alarms:

Sensor Zero Output Out of Bounds

EEPROM Failure

Valve Coil Failure or Valve Disconnected

Temperature Out of Operating Range

After power up the LED on the top of the CS230A MFC/MFM is turned GREEN. A warning condition will be announced by a blinking RED and whenever an alarm condition is detected it will be set continuously to RED.

Please refer to “Digital MFC Communication User Manual” for more details.

3.11 LED

There is a green-red LED located on the top of the MFC. The constant green LED indicates the power on. Green blinking indicates that the MFC is zeroing. A blinking red LED indicates warning condition. Constant red indicates error condition.

Attention

When Valve controller of MFC is posited on position of “PURGE”, it can be functioned as a MFM. In that case, the maximum flow testing voltage could reach beyond +10V, please be careful, while flow is beyond F.S. +5V(Full Scale), the real flow will have no linearity corresponding with flow testing voltage. While it's purging, flow display will be inaccurate, even showing “reduce” while the real flow is enhanced, please be sure it'll be no damaged to device itself.

SECTION 4 MAINTENANCE

4.1 General

No routine maintenance is required to be performed on the MFM or MFC, Other than occasional cleaning and re-calibration:

It can be used about 3 or 4 years with an ultra-clean and non corrosive gas.

It can be used about 1 or 2 years with a low purity gas or a corrosive gas.

For any other problems, contact Sevenstar.

4.2 Caution

4.2.1 Medium Forbidden

The used gas should be purified without dust, liquid and oil stain. If necessary, the

filter should be added to gas system for purification. If the outlet of MFC is connected to liquid sources, a One-way valve should be added to avoid the liquid back to destroy MFC.

Attention :

For the cases that the MFC/MFM used with toxic, pyrophoric, flammable or corrosive gas, you should ensure that the fixing and fitting are airtight. It becomes necessary to remove the controller from the system, purge the controller thoroughly with a dry inert gas such as nitrogen, before disconnecting the gas connections. Failure to purge the controller could cause a fire or explosion resulting in death.

4.2.2 Seal of Valves

The Solenoid Valve of MFC is only for adjustment, can not be used for shut-off. Generally, shut-off valves should be added in upstream and downstream of MFC for protection. Normally leakage of MFC valve is not more than 1% F.S.

SECTION 5 TROUBLESHOOTING

5.1 Initial Check

5.1.1 Check the gas supply pressure and check the flow-path to the MFC/MFM has been opened.

5.1.2 Ensure that the power supply and command signals are correctly transmitted to the D-connector pins and RS485.

5.1.3 Check that the output signal matches the external reading.

5.2 Troubleshooting

Use the following table to locate the fault.

	SYMPTOMS	Possible cause	Action
1	Output reading, without gas flow, is not zero	Gas flow is actually present	Check closure of series shutoff valve
		Zero drift	Zero MFC

		other	*Contact Sevenstar
2	MFC will not control	Gas connection incorrect	Check gas connection
		Pressure incorrect	Check pressure condition
		Wrong control mode	Change the control mode by the software
		Power failure	Check Power and pin position
		Setpoint incorrect	Check setpoint signal
		Contamination	*Contact Sevenstar
		Defective sensor	*Contact Sevenstar
		PCB problems	*Contact Sevenstar
		Defective Mechanics	*Contact Sevenstar
3	MFC will not communicate with PC	Power failure	Check Power and pin position
		Cable problems	Check cable and connector
		Address conflict	Check address of MFC
		Baud rate error	Check baud rate of MFC
		PCB problems	*Contact Sevenstar

Attention 

* Mark indicates that reparation and adjustment must be dealt under specialist advices. For any other problems, contact Sevenstar.

SECTION 6 WARRANTY AND SERVICES

6.1 Guarantee of Sevenstar

Sevenstar and its authorized distributors assure that there are not flaws in the materials and quality of products within 12 months from the date of purchase.

The compensation for customer is only limited to invalid part for substitution, installation and processing flaw.

It is guaranteed that all parts chosen by customers are suitable to relative manufacturer.

Other relative statements, guarantee and obligation of status and usage of product,

whether direct or indirect, are definite to be excluded. In any circumstance, Sevenstar is not charged of any obligation of direct or indirect loss for customers or others.

6.2 Product Warranty

6.2.1 Sevenstar products are guaranteed against defects in materials and workmanship if used in accordance with specifications and not subject to physical damage, contamination, alteration or retrofit. Warranty periods: One year

6.2.2 Buyers undertake to check and inspect the goods and to notify Sevenstar of shipment incidents by fax, phone or e-mail as soon as possible after accepting the goods.

6.2.3 During the warranty period, products must only be repaired by authorized Sevenstar service centers; otherwise, the Sevenstar product warranty will be invalidated.

6.2.4 Repairs will be free of charge during the one-year warranty period. If MFC is out of warranty, Sevenstar will notify the owner of replacement or repair costs before proceeding. Factory service and repairs are guaranteed 90 days. The warranty excludes consumable materials and wear parts (in teflon, viton, etc.).

6.2.5 No MFC will be accepted for repair or warranty without a decontamination and purge certificate.

6.2.6 Each MFC is individually checked (visual inspection of fittings, helium leak test and flow calibration). Sevenstar shall not be responsible for any damage caused by gas leakage or the use of a dangerous gas. Users are responsible for following the safety rules applicable to each gas they use. Improper use of a Sevenstar MFC will void the warranty, and MFC that have been damaged as a result of improper use will not be replaced by Sevenstar.

6.2.7 Specific warranty requirements are as follows :

a, Gas must be clean and particle-free, which means a filter must be fitted in the gas line upstream of the MFC.

b, Gas must comply with the following pressure specifications:

1. Gas pressure must never exceed 3MPa.
2. Differential pressure must be more than 0.05MPa for full-scale flow through the MFC valve unless another value is specified in the user's manual.
3. Differential pressure must be less than 0.35MPa for the MFC valve to regulate without gas-flow oscillation unless another value is specified in the user's manual.
4. Pressure at the mass-flow inlet must be regulated by an accurate pressure regulator to prevent gas-flow oscillation.

c, Electrical connection requirements are as follows:

The system must be wired carefully: non-observance of the pin-out may irreversibly damage the electronic board inside the MFC, in which case the warranty will be invalidated.

d, Gas connections: The fittings must be handled carefully. Sevenstar guarantees that all fittings have been individually inspected and are scratch-free.

e, Fitting procedure: The fitting procedure set out in the manual must be followed meticulously. Specifically, the purge procedure is very important if corrosive gases or toxic gases are used.

f, The mass-flow must not be dismantled: The MFC warranty will be invalidated if the seal between the MFC block and cover is torn.

6.3 Services

Sevenstar can provide services like start-up service, software development, gas system design, training, etc.

Please visit www.mfcsevenstar.cn for more information and find your nearest service and calibration centre.

6.4 Disclaimer

Beijing Sevenstar Electronics Co., Ltd is not responsible for loss as following situation:

1. Nature disaster and calamity;
2. Unsuitable operation and unreasonable usage;
3. Operating and storing in inappropriate or execrable circumstance;
4. Usage of instrument beyond user's manual;
5. Unauthorized change or replacement of product.

For example:

It is whether that gas path is not cleared before using corrodible gas or MFC is contaminated or blocked by particle such as dust.

Appendix I CS230 Selection Guide

CS230 [t] [g,g,g] [v] [r,r,r,r] [a] [f,f] [s] [m] [d]

[t] -Type

- [A] Elastomer type

[g,g,g] -Gas

Standard: SEMI52-0302 For example

- [013] N₂

- [007] H₂

- [000] Mixture Gases (please consult [d] for details)

[v] - Type of Valve

- [C] Normally closed (unavailable to MFM)

- [N] No Valve (available to MFM only)

[r,r,r,r] -Full Scale

- [050L] 50SLM

- [100L] 100SLM

- [150L] 150SLM

- [200L] 200SLM

- [250L] 250SLM

- [300L] 300SLM

- [000C] customized Full scale, please consult [d] for details

[a] -Electronic connector

- [R] DB 9 pin - [D] DB15 pin

- [X] DeviceNet™

[f,f] -Fittings

- [GG] Compression Fittingφ 6mm (Flow(N₂)≤60SLM)

- [DD] Compression Fittingφ 8mm (Flow(N₂)≤200SLM)

- [JJ] Compression Fittingφ 10mm

- [SS] Compression Fittingφ 12mm

- [CC] Compression Fitting 1/4" (Flow(N₂)≤60SLM)

- [HH] Compression Fitting 3/8"

- [PP] Compression Fitting 1/2"

- [EE] VCR 1/2"

- [XX] customized fittings please consult [d] for details

[s] -Seal Materials

- [V] Viton

- [N] N eoprene

[m] -Mounting Position

- [H] Horizontal

- [E] HESD(Horizontal Edge Side Down)

- [U] Vertical Inlet Up

- [D] Vertical Inlet Down

[d] -Description

- [-]: Default Value

The letters on cover and tag: In English

Differential Pressure

CS230-□XXXC:

- 50 SLM ≤ Flow(N₂) < 150 SLM: (0.15~0.35) MPa (21.8~50.8 psid)
- 150 SLM ≤ Flow(N₂) ≤ 250 SLM: (0.20~0.35) MPa (29.0~50.8 psid)
- 250 SLM < Flow(N₂) ≤ 300 SLM: (0.25~0.40) MPa (36.3~58.0 psid)

CS230-□XXXN:

- 50~100 SLM: <0.02 MPa (2.9 psid)
- > 100 SLM: <0.05 MPa (7.3 psid)

-[S] Customized Requirement

For Example: The letters on cover and tag: in Chinese: Customer Special Full Scale: 29 SLM; The proportion of mixture gases should be indicated: N₂ (60%) + CO₂ (40%); Customer Differential Pressure: (0.3~0.5) MPa; Customer Calibration Temperature: 40°C and other customized requirements.

Take CS230A013C050LDGGVHS as the example

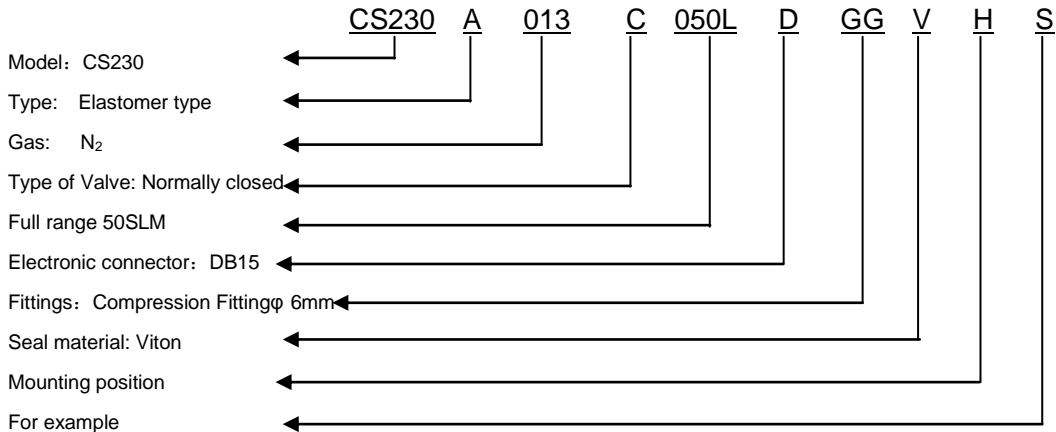

Customized requirement: In Chinese. Differential pressure, (0.3-0.5) MPa, customized fittings, customized calibration temperature, 40°C

APPENDIX II CONVERSION FACTOR

GAS	GAS CODE (SEMIE52-0302)	SPECIFIC HEAT (Cal/g °C)	DENSITY (g/1 0°C)	CONVERSION FACTOR
Air	008	0.2400	1.2930	1.001
Ar	004	0.1250	1.7837	1.420
AsH ₃	035	0.1168	3.4780	0.673
BBr ₃	079	0.0647	11.1800	0.378
BCl ₃	070	0.1217	5.2270	0.450
BF ₃	048	0.1779	3.0250	0.508
B ₂ H ₆	058	0.5020	1.2350	0.441
CCl ₄	101	0.1297	6.8600	0.306
CF ₄	063	0.1659	3.9636	0.420
CH ₄	028	0.5318	0.7150	0.722
C ₂ H ₂	042	0.4049	1.1620	0.596
C ₂ H ₄	038	0.3658	1.2510	0.597
C ₂ H ₆	054	0.4241	1.3420	0.482
C ₃ H ₄	068	0.3633	1.7870	0.421
C ₃ H ₆	069	0.3659	1.8770	0.411
C ₃ H ₈	089	0.3990	1.9670	0.358
C ₄ H ₆	093	0.3515	2.4130	0.322
C ₄ H ₈	104	0.3723	2.5030	0.299
C ₄ H ₁₀	117	0.4040	2.6500	0.261
C ₅ H ₁₂	240	0.3916	3.2190	0.217
CH ₃ OH	176	0.3277	1.4300	0.584
C ₂ H ₆ O	136	0.3398	2.0550	0.392
C ₂ H ₃ Cl ₃	112	0.1654	5.9500	0.278
CO	009	0.2488	1.2500	1.000
CO ₂	025	0.2017	1.9640	0.739
C ₂ N ₂	059	0.2608	2.3220	0.451
Cl ₂	019	0.1145	3.1630	0.858
D ₂	014	1.7325	0.1798	0.997
F ₂	018	0.1970	1.6950	0.931
GeCl ₄	113	0.1072	9.5650	0.267

GAS	GAS CODE (SEMIE52-0302)	SPECIFIC HEAT (Cal/g °C)	DENSITY (g/10 °C)	CONVERSION FACTOR
GeH ₄	043	0.1405	3.4180	0.570
H ₂	007	3.4224	0.0899	1.010
HBr	010	0.0861	3.6100	0.999
HCl	011	0.1911	1.6270	0.988
HF	012	0.3482	0.8930	1.001
HI	017	0.0545	5.707	1.000
H ₂ S	022	0.2278	1.5200	0.802
He	001	1.2418	0.1786	1.420
Kr	005	0.0593	3.7390	1.431
N ₂	013	0.2486	1.2500	1.000
Ne	002	0.2464	0.9000	1.431
NH ₃	029	0.5005	0.7600	0.719
NO	016	0.2378	1.3390	0.978
NO ₂	026	0.1923	2.0520	0.737
N ₂ O	027	0.2098	1.9640	0.710
O ₂	015	0.2196	1.4270	0.981
PCl ₃	193	0.1247	6.1270	0.358
PH ₃	031	0.2610	1.5170	0.690
PF ₅	143	0.1611	5.6200	0.302
POCl ₃	102	0.1324	6.8450	0.302
SiCl ₄	108	0.1270	7.5847	0.284
SiF ₄	088	0.1692	4.6430	0.348
SiH ₄	039	0.3189	1.4330	0.600
SiH ₂ Cl ₂	067	0.1472	4.5060	0.416
SiHCl ₃	147	0.1332	6.0430	0.340
SF ₆	110	0.1588	6.5160	0.258
SO ₂	032	0.14890	2.8580	0.687
TiCl ₄	114	0.1572	8.4650	0.206
WF ₆	121	0.0956	13.2900	0.217
Xe	006	0.0379	5.8580	1.431



Beijing Sevenstar Flow Co.,Ltd.

CS Series

Mass Flow Controller

Beijing Sevenstar Flow Co., Ltd.

Address: No.1 Jiuxianqiao East Rd., Chaoyang District, Beijing, China
P.O.BOX 3#741, Beijing, China
Post code: 100015
Tel: (+86)-10-64361831 ext. 8527
Fax: (+86)-10-64362923
Homepage: www.mfcsevenstar.cn
E-Mail: mfcsales@sevenstar.com.cn

Shanghai Office: Rm.722 Bldg.29, No.368, Zhangjiang Rd, Pudong New Area,
Shanghai, China

Tel: (+86)-21-63532370
Fax: (+86)-21-63533265

Shenzhen Office: Room 712, Section B, Qiche Tower, No.45 Zhenhua Road,
Futian District, Shenzhen, China

Zip code: 518031
Tel: (+86)-755-88290258
Fax: (+86)-755-88294770

*Description may be changed following improvements to product. The information contained in this document is subject to change without notice

*If there is any mistake in this uses manual, please feel free to contact us.

*©2010 Beijing Flow Co.,Ltd.

All rights reserved.